

MODEL SY-40 Series STRAINER

PRODUCT MANUAL

Thank you very much for choosing the Yoshitake's product. To ensure the correct and safe use of the product, please read this manual before use. This manual shall be kept with care for future references.

The symbols used in this manual have the following meanings.



	Warning	This symbol indicates a potentially hazardous situation that, if not avoided, could result in death or serious injury.
	Caution	This symbol indicates a hazardous situation that, if not avoided, may result in minor or moderate injury or may result in only property damage.

Table of Contents

Usage of the product.....	1
1. Features	1
2. Specifications.....	1
3. Dimensions and weights.....	2
4. Operating mechanism.....	3
5. Selection of nominal size	
5.1 Selection of nominal size	4
5.2 Selection of piping nominal size.....	4
5.3 Nominal size selection chart	5
6. Installation procedure	
6.1 Example of piping.....	6
6.2 Caution in installing the product.....	6-7
7. Operation procedure	
7.1 Caution in operating the product.....	7
8. Maintenance procedure	
8.1 Troubleshooting	7
8.2 Caution in maintenance and inspection	8
8.3 Disassembly procedure	8
8.4 Caution in assembling after disassembly	8
8.5 Assembly procedure	8
9. Exploded view.....	9
Information on after-sales services	



Usage of the product

The product is widely used for dust removal from various types of pipelines. Especially, a strainer shall be installed upstream of a pressure reducing, temperature regulating, solenoid or trap valve to protect and maintain it.

1. Features

- (1) The product is a high-flow marine type with as large a filtration area as possible to avoid clogging and consequent problems such as flow rate drop.
- (2) Ones with a nominal size of 65A or above have been downsized to the possible minimum sizes and thus ease the piping.
- (3) SY-40C/40C-N is highly resistant to corrosion as it has the internal and external body surfaces coated with nylon 11 or nylon 12.
- (4) For the standard screens, 80 mesh ones are used for SY-40/40H and 60 mesh ones for SY-40C/40C-N according to the common specifications for machinery and equipment installation work.

2. Specifications

Model		SY-40	SY-40C	SY-40C-N	SY-40H
Nominal size		15-300A			15-150A
Application		Steam, air, hot or cold water, Oil and other non-dangerous fluids	Air, hot or cold water and other non-dangerous fluids		Steam, air, hot or cold water and other non-dangerous fluids
Maximum pressure		1.0MPa			2.0MPa
Maximum temperature		220°C	60°C		220°C
Material	Body	Ductile cast iron			
	Screen	Stainless steel			
Connection		JIS 10K FF flanged			JIS 20K FF flanged
Standard screen	Perforations	$\phi 2.5 - 7.21$ holes/cm ²			
	Mesh	80 mesh	60 mesh		80 mesh

- SY-40C has the external and internal body surfaces coated with nylon 11 (15A to 200A) or nylon 12 (250A and 300A).
- SY-40C-N has the external and internal body surfaces coated with nylon 12 (15A to 150A).
- Ones with 20 to 100 mesh filter are also available upon request.
- Ones with single layer of perforations are also available upon request.
 Nominal size 15 to 80A... $\phi 1.3 - 16.2$ holes/cm²
 100A or above... $\phi 1.5 - 11.2$ holes/cm²
- Ones with brass plug may also be manufactured.(except for SY-40C-N)
- Rust-proof (hot dip galvanized) ones are also available with nominal sizes of 65A or above.(except for SY-40C/40C-N)

3. Dimensions and weights

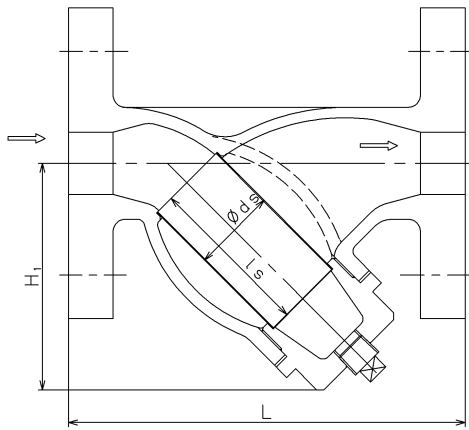

[Figure 1] 15-50A

(No plug is provided with 15 to 32A ones.)

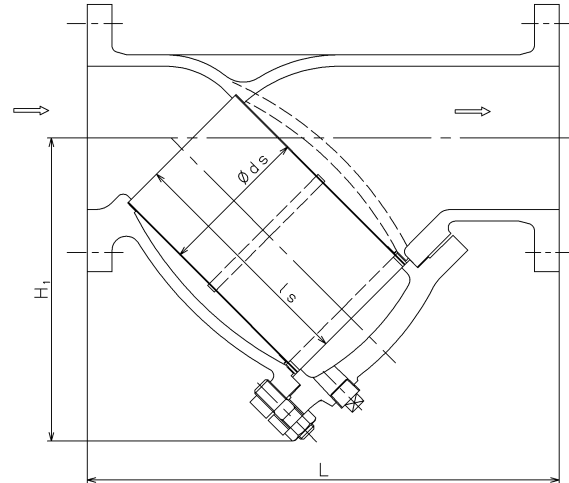

[Figure 2] 65-300A

■ SY-40, 40C, 40C-N

(mm)

Nominal size	L	H ₁	ds	L _s	Connection	Weight (kg)
15A	130	61	22	40	---	1.9
20A	140	75	27	56	---	2.5
25A	160	88	34	66	---	4.0
32A	175	104	43	76	---	5.2
40A	190	115	50	85	R 1/2	6.7
50A	225	140	61	107	R 1/2	10.2
65A	255	167	73	125	R 1/2	14.5
80A	330	190	88	130	R 1/2	18.3
100A	370	225	108	180	R 3/4	29.7
125A	415	263	136	200	R 3/4	40.5
150A	495	315	160	250	R 3/4	66.0
200A	565	385	210	300	R 3/4	95.8
250A	690	460	260	370	R 3/4	167.5
300A	840	556	315	442	R 3/4	286.0

■ SY-40H

(mm)

Nominal size	L	H ₁	ds	L _s	Connection	Weight (kg)
15A	130	61	22	40	---	1.9
20A	140	75	27	56	---	2.5
25A	160	88	34	66	---	4.0
32A	175	104	43	76	---	5.2
40A	190	115	50	85	R 1/2	6.7
50A	233	140	61	107	R 1/2	10.2
65A	290	167	73	125	R 1/2	15
80A	316	190	88	130	R 1/2	19
100A	360	225	108	180	R 3/4	28
125A	415	263	136	200	R 3/4	42
150A	495	315	160	250	R 3/4	68

4. Operating mechanism

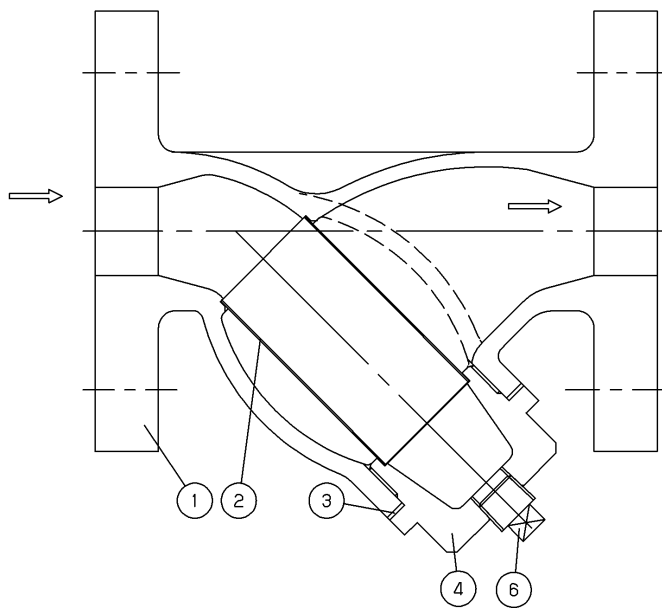

[Figure 3] 15-50A
(No plug is provided with 15 to 32A ones)

No.	Part name
1	Body
2	Screen
3	Gasket
4	Cap
5	Cover
6	Plug
7	Strainer retainer
8	Hexagon nut
9	Stud bolt
10	Washer

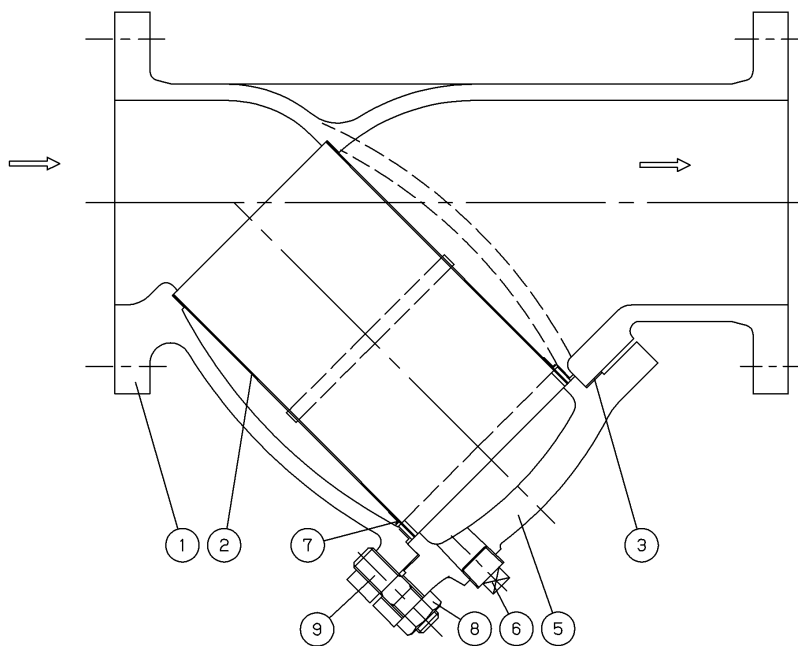

[Figure4] 65-300A
(No strainer retainer is provided with 65 to 80A ones.)

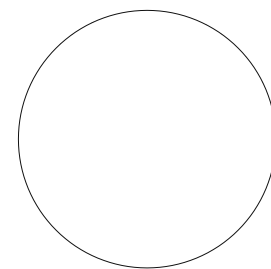

SY-40C/40C-N
SIZE: 65A~300A

Dust, scale and other foreign matter from the fluid flowing into the strainer through the inlet port are removed by the screen (2).

5. Selection of nominal size

To make the best use of the strainer and satisfy the operating requirements to the maximum, take notice of the following.

The preferred initial pressure loss is 0.02-0.03 MPa.

5.1 Selection of nominal size

Select a nominal size equivalent to that of the pipe (piping nominal size = nominal size of strainer). Note that the use of a smaller nominal size increases the pressure loss through the strainer, possibly reducing the machine inlet pressure below the specified limit.

5.2 Selection of piping nominal size

When selecting the piping nominal size, it is necessary to consider the fluid type, maximum flow rate, permissible pressure loss, piping and equipment cost, etc. With a smaller piping nominal size, the piping and equipment cost decreases but the pressure loss through the pipe increases to generate disturbances, possibly resulting in pipe wear, noise and/or vibration. With too large a piping nominal size, however, not only the piping and equipment cost but also the thermal loss increase. The standard fluid velocity has been specified in the Japanese Industrial Standards (JIS) as a guide to select an appropriate piping nominal size.

<<Standard fluid velocity>>

Fluid	Remarks	Standard flow velocity
Saturated steam	Auxiliary piping for vacuum or small-diameter piping	15 m/s (10-20)
	Large-diameter piping	30 m/s (20-40)
Superheated steam	Piping diameter: approx. $\phi 75 - \phi 250$	40 m/s (30-50)
	Piping of high-grade material	70 m/s (65-80)
Inlet of steam coil	0.3-0.7MPa	30 m/s (25-30)
Air	Higher pressure: 1.0 MPa or more	20 m/s (20-25)
	Lower pressure	15 m/s (5-15)
	Extremely low pressure: 0.1 MPa or less	10 m/s (3-10)
Water or oil		2 m/s (2- 4)

* This table shows a standard flow velocity of each type of fluid set based on the requirements defined in JIS F 7101 (Shipbuilding – Pipes of machinery – Standard velocity of flow).

5.3 Nominal size selection chart (Fluid: Water)

- Screen: $\phi 1.3-16.2$ holes/cm² ($\phi 1.5-11.2$ holes/cm²) perforations without mesh filter
- - - - - Screen: $\phi 2.5-7.21$ holes/cm² perforations with 80 mesh filter

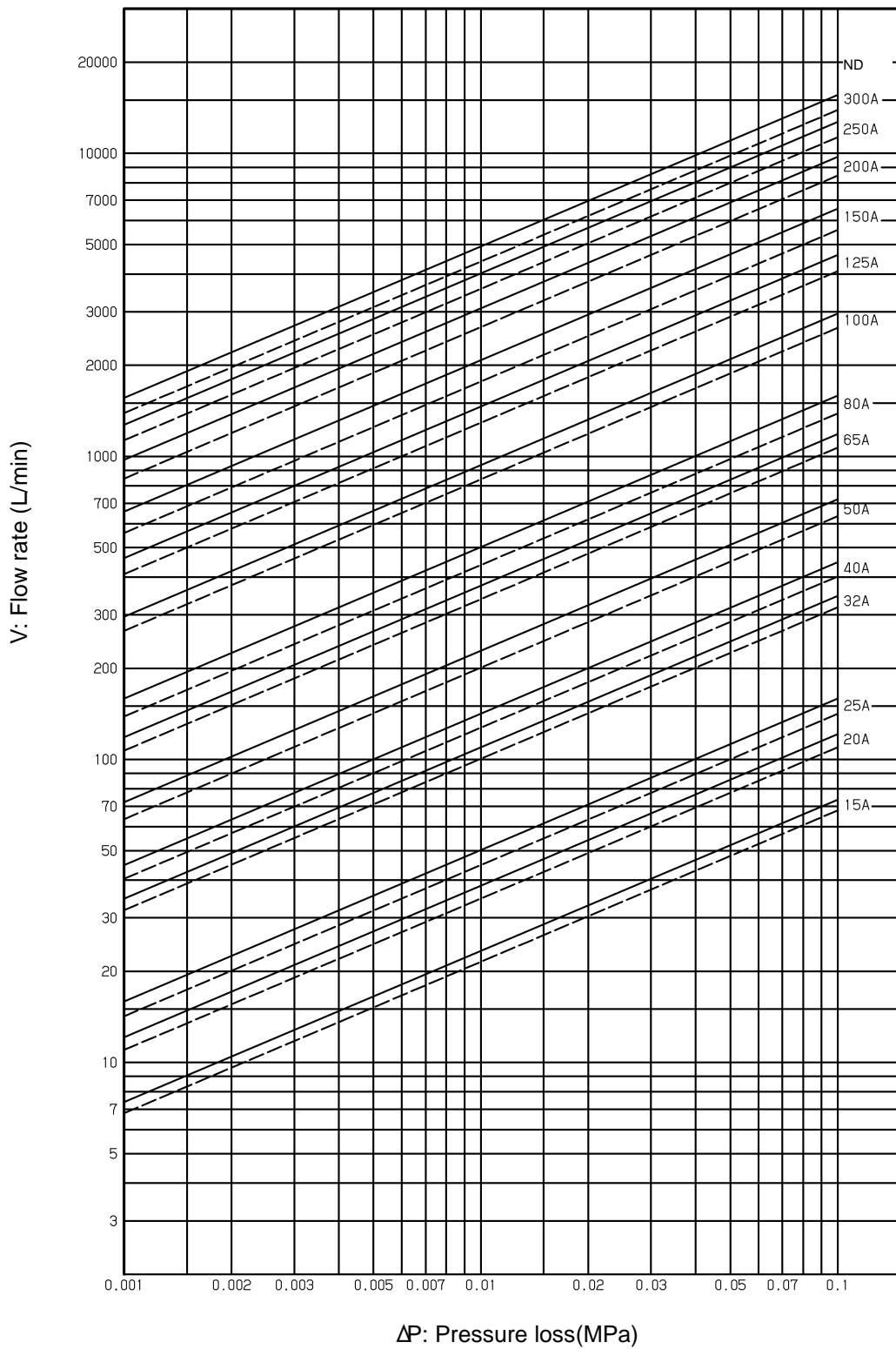

6. Installation procedure

6.1 Example of piping

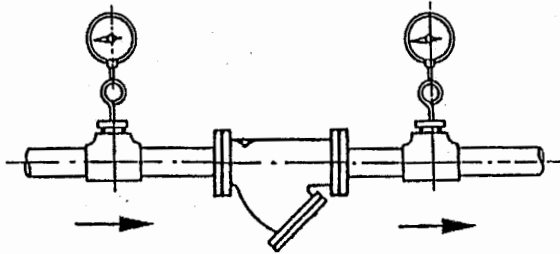

[Figure 5] Horizontal piping

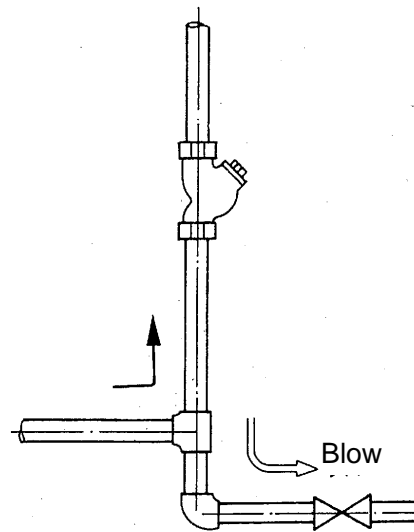

[Figure 6] Vertical piping

- (1) The amount of clogging matter may be estimated from the differential pressure measured with pressure gauges installed upstream and downstream of the strainer. (See Figure 5.)
- (2) They shall be installed with the cap (4) or cover (5) facing downward. If drainage or similar problem may occur in a steam line, the cap (4) or cover (5) shall be installed so that the cap or cover faces sideways.
- (3) If the product can only be piped to run the fluid from the bottom to the top, a blow valve shall be installed to remove the scale accumulated at the bottom of the riser pipe. (See Figure 6.)

6.2 Caution in installing the product

Warning

- (1) The product is heavy and shall be securely suspended with a hoist or the like when installed. For the weight of the product, see section 3 "Dimensions and weights."
* Failure to suspend the product may cause it to fall down, possibly resulting in injury.

Caution

- (1) When installing, install the pipe so that the fluid flowing direction follows arrow on the body.
* Connecting pipes in wrong directions prevents the product from performing as intended.
- (2) Firmly support pipes and secure the product.
* If an excessive stress is applied to the pipes, the product may be deformed.
- (3) When installing the product, reserve a space required for maintenance and inspection (cleaning of the screen) as specified in Figure 7.
* Failure to do so prevents later maintenance and inspection (cleaning of the screen).
- (4) Firmly connect pipes.
* If incompletely connected, the fluid may leak from pipes when vibration is applied. The fluid may scald your skin.
- (5) If no foreign matter is allowed to pass through the product, please contact us.
* The foreign matter corresponding to the specified mesh size may not be completely caught constitutionally.

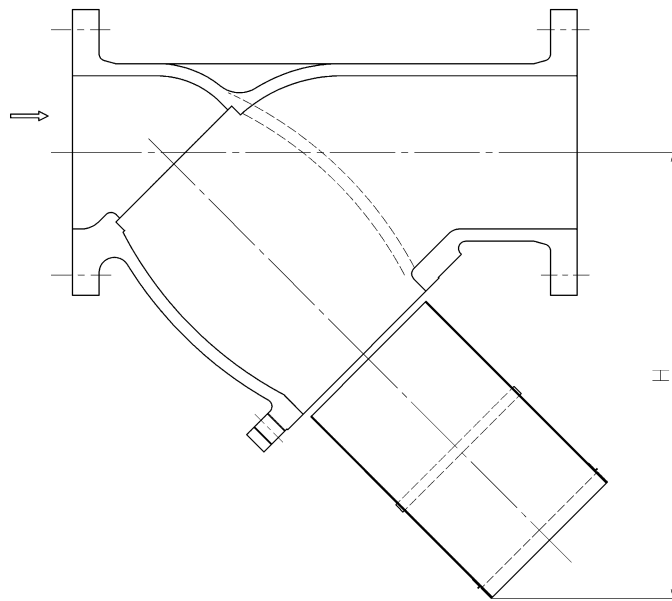

[Figure 7] Space for removing the screen

(mm)	
Nominal size	H
15A	80
20A	105
25A	125
32A	145
40A	160
50A	200
65A	220
80A	245
100A	310
125A	365
150A	445
200A	550
250A	675
300A	805

7. Operation procedure

7.1 Caution in operating the product

Warning

- (1) Before letting the fluid into the product, check that there will be no possibility of danger if fluid flows into the ends of piping.
 - * The hot fluid, if spouted out, may scald your skin.
 - * The fluid outflow may cause physical damage.
- (2) After aerating, do not retighten the cap or cover gasket.
 - * Doing so may break the gasket, possibly resulting in external leak.

Caution

- (1) Use the product with the maximum pressure loss below 0.1MPa. Periodically clean the screen.
 - * The screen may be broken.

- (1) The amount of screen clogging matter can be monitored with pressure gauges installed upstream and downstream of the strainer.

8. Maintenance procedure

8.1 Troubleshooting

Problem	Cause	Solution
Fluid does not flow.	<ol style="list-style-type: none"> 1. Screen (2) is clogged. 2. Upstream and downstream of stop valves are closed. 	<ol style="list-style-type: none"> 1. Overhaul and clean screen (2). 2. Open the stop valves.
Excessive pressure loss	<ol style="list-style-type: none"> 1. Screen (2) is clogged. 2. Pressure gauge is out of order. 3. Nominal size is much smaller than specified. 	<ol style="list-style-type: none"> 1. Overhaul and clean screen (2). 2. Replace pressure gauge with a new one. 3. Change to adequate nominal size.

8.2 Caution in maintenance and inspection

Warning

- (1) When overhauling or inspecting the product, check that the product and piping internal pressures have been released to the atmosphere.
When the fluid is hot, cool it down until it can be touched by bare hand.
*The residual pressure in the product or piping may lead to injury or burn.
- (2) When using a hot fluid, do not touch the product by bare hand.
*Doing so may scald your skin.
- (3) Clean the screen periodically.
*Scale clogging to the screen may cause its damage.

8.3 Disassembly procedure

- (1) After checking that no pressure remains in the strainer, remove the cap (4) and gasket (3) for 50A or smaller ones or the hexagon nut (8), cover (5) and gasket (3) in this order for 65A or larger ones.
- (2) Remove the screen (2) from the body (1) and clean it. For 100A or larger ones, the screen (2) is equipped with a strainer retainer (7). The strainer retainer (7) has usually been hung on the body (1) and the screen (2) shall be removed by rotating to the point where the notch on the body (1) is aligned with the strainer retainer (7). (See Figure 8.)

8.4 Caution in assembling after disassembly

Caution

- (1) When assembling, completely assemble all parts.
*The parts may be deformed or broken.
- (2) When assembling, replace the gasket with a new one and uniformly tighten bolts in the diagonally opposite directions to prevent uneven tightening.
*The fluid may leak out. If hot, it may scald your skin.
- (3) For the size 50A or less of SY-40C/40C-N, before assembly, apply water proof seal agent (recommendation: KS-64 by Shin-Etsu Chemical Co., Ltd.) to screw part and gasket contact surface.
* If water proof seal agent is not applied, it may be stuck due to rust generation.

8.5 Assembly procedure

- (1) Clean the gasket mating faces of the body (1) and cap (4) or cover (5) and install the cleaned screen (2) to the body (1). For 100A or larger ones, the screen (2) shall be installed with the strainer retainer (7) aligned with the notch on the body (1) and rotated until the strainer retainer (7) is hung on the body (1). (See Figure 8.)
- (2) Install a new gasket (3) and install the cap (4) or cover (5).

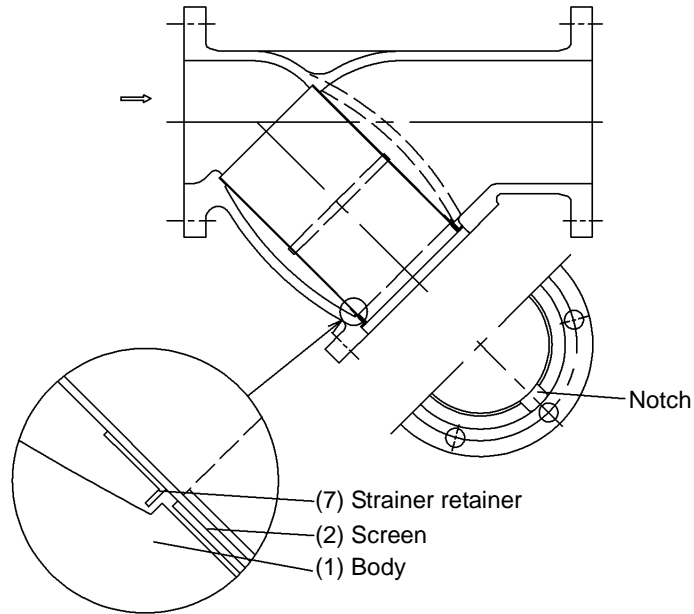

9. Exploded view

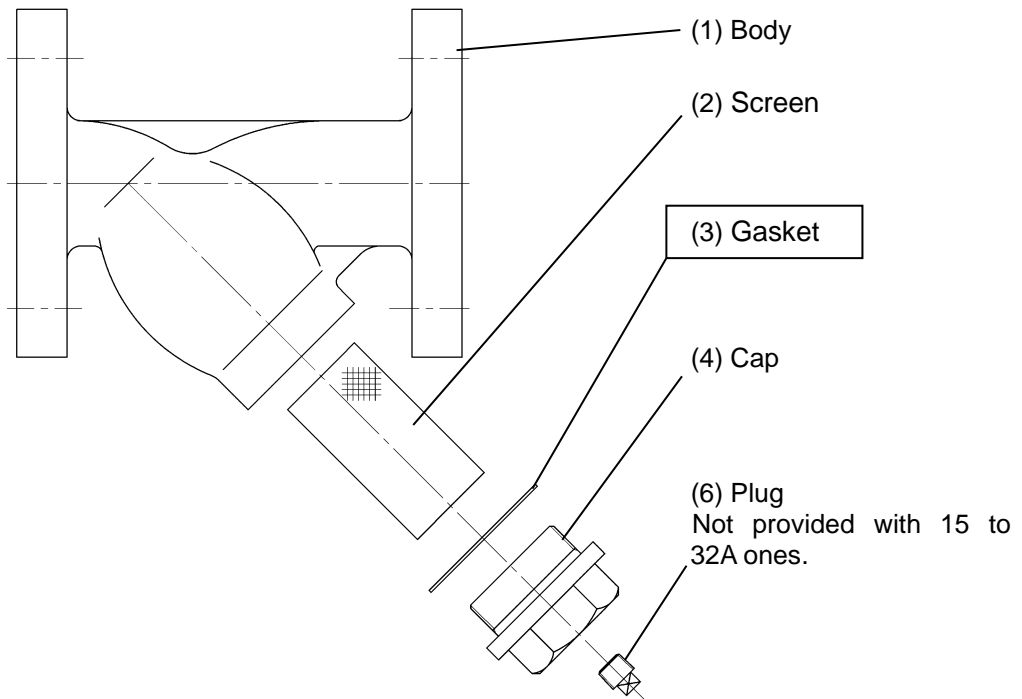

[Figure 9] 15 to 50A

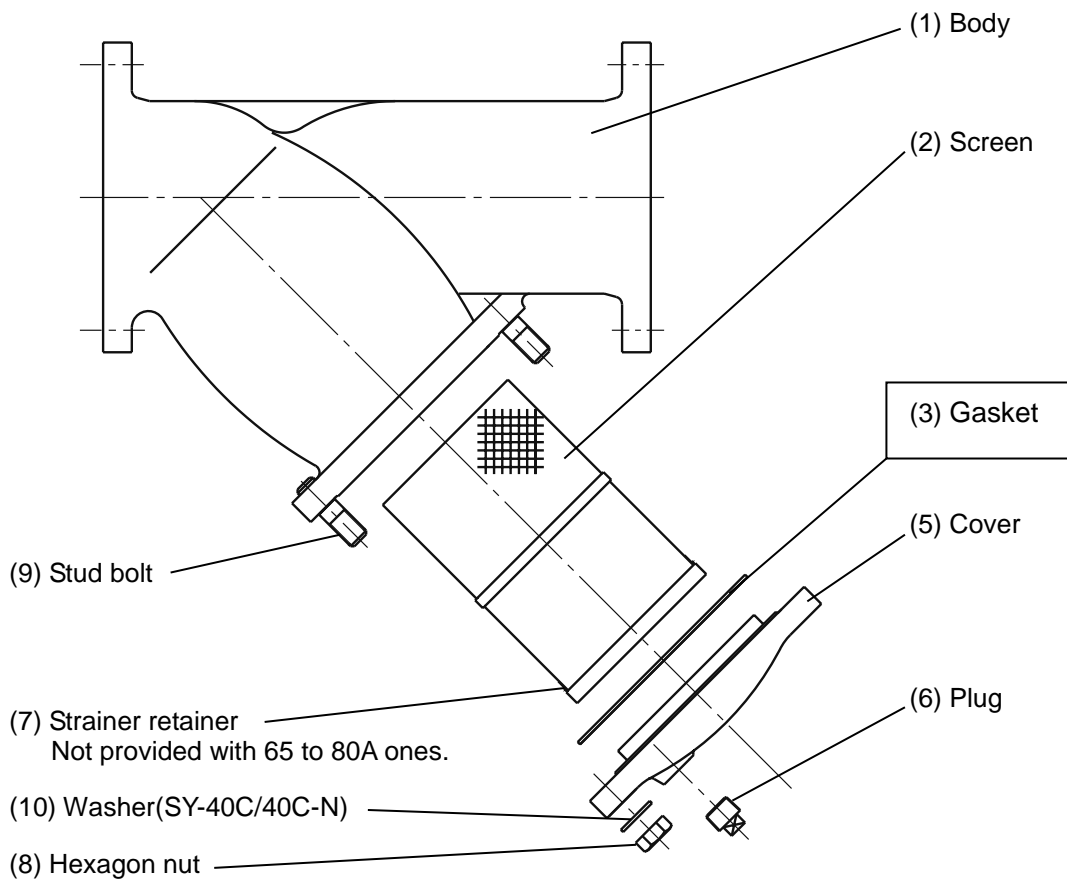

[Figure 10] 65 to 300A

is provided as consumable parts.